

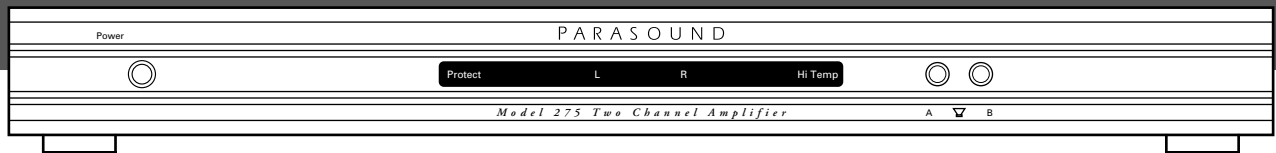

PARASOUND

NEW CLASSIC



Model 275

Two Channel Power Amplifier

OWNER'S GUIDE



IMPORTANT SAFETY INSTRUCTIONS

The lightning flash with the arrowhead symbol within an equilateral triangle is intended to alert the user to the presence of “dangerous voltage” inside the product that may constitute a risk of electric shock.

The exclamation point within an equilateral triangle is intended to alert the user to the presence of important operating and maintenance instructions in the literature accompanying the product.

TO REDUCE THE RISK OF ELECTRIC SHOCK, DO NOT REMOVE COVER. NO USER-SERVICEABLE PARTS INSIDE. REFER SERVICING TO QUALIFIED SERVICE PERSONNEL

1. **Read Instructions** — Read all the safety and operating instructions before operating this product.
2. **Retain Instructions** — Retain safety and operating instructions for future reference.
3. **Heed Warnings** — Adhere to all warnings on the product and in the operating instructions.
4. **Follow Instructions** — Follow all operating and use instructions.
5. **Cleaning** — Unplug this product from the wall outlet before cleaning. Use a damp cloth for cleaning. Clean the outside of the product only.
6. **Attachments** — Do not use attachments that are not recommended by the product manufacturer; they may be hazardous.
7. **Water and Moisture** — Do not use this product near water.
8. **Accessories** — Do not place this product on an unstable cart or stand. The product may fall, causing bodily injury and damage to the product. A product and cart combination should be moved with care. Quick stops, excessive force, and uneven surfaces may cause the product and cart to overturn.
9. **Ventilation** — Slots and openings in the cabinet are provided for ventilation to ensure reliable operation of the product and to protect it from overheating. These openings must not be blocked or covered. This product should not be placed in a built-in installation such as a bookcase or rack unless proper ventilation is provided.
10. **Power Sources** — Operate this product only from the type of power source indicated on the label. If you are not sure of the type of power supply to your home, consult your dealer or local power company. This product is equipped with a three-prong grounding plug. This plug will only fit into a grounding power outlet. If you are unable to insert the plug into the outlet, contact your electrician to replace your obsolete outlet. Do not defeat the safety purpose of the grounding plug.
11. **Power Cord Protection** — Power supply cords should be routed so that they are not likely to be walked on or pinched by items placed upon or against them.
12. **Lightning** — Unplug the unit from the wall outlet for added protection during a lightning storm and when it is left unattended and unused for long periods of time. This will prevent damage to the product due to lightning and power line surges.
13. **Overloading** — Do not overload wall outlets or extension cords. This can result in a fire or electric shock.
14. **Inserting Objects into Unit** — Never push objects of any kind into this product through any openings; they may touch dangerous voltage points or short out parts that could result in fire or electric shock.
15. **Servicing** — Do not attempt to repair or service this product yourself. Opening or removing covers may expose you to dangerous voltage and other hazards. Refer all servicing to qualified service personnel.
16. **Damage Requiring Service** — Unplug this product from the wall outlet and refer servicing to qualified service personnel under the following conditions: **a)** If the power-supply cord or plug is damaged. **b)** If liquid has been spilled into the product. **c)** If the product has been exposed to rain or water. **d)** If the product does not operate normally by following the operating instructions. **e)** If the product has been dropped or damaged in any way. **f)** If the product exhibits a distinct change in performance.
17. **Replacement Parts** — When replacement parts are required, be sure the service technician has used replacement parts specified by the manufacturer. Unauthorized substitutions may result in fire, electric shock, and other hazards.
19. **Safety Check** — Upon completion of any service or repairs to this product, ask the service technician to perform safety checks to determine that the product is in proper operating condition.
20. **Wall or Ceiling Mounting** — Mount the product to a wall or ceiling only as recommended.
21. **Heat** — The product should be situated away from heat sources such as radiators, heat registers, stoves, and other products (including amplifiers) that produce heat.

<i>Unpacking and Accessories</i>	2
<i>115v – 230v AC Selector Switch</i>	3
<i>Ventilation Requirements</i>	3
<i>Rack Mounting</i>	3
<i>Rear Panel Connections and Controls</i>	4
<i>Input and Loop Out Jacks</i>	4
<i>Level Knobs</i>	4
<i>High Pass Filter Switch</i>	4
<i>Speaker Connections</i>	5
<i>Bridging Switch: Stereo - Mono</i>	5
<i>Mono Input</i>	6
<i>Speaker Connections</i>	6
<i>Load Impedance Switch</i>	6
<i>Auto Turn On</i>	6
<i>Sensitivity Adjust Knob</i>	8
<i>Ground Switch</i>	8
<i>Front Panel Power Button and Speaker Buttons</i>	9
<i>Front Panel Status Indicators</i>	9
<i>Typical Problems and Remedies</i>	10
<i>Are You Having Difficulty?</i>	11
<i>Warranty Repair</i>	11
<i>Specifications</i>	12
<i>Connection and Setup Notes</i>	13

Congratulations and thank you for your purchase of this precision Parasound audio component. The Parasound Model 275 is the latest generation of popular and proven audio power amplifiers dating back to 1981. It has been designed for a wide variety of applications, establishing a new standard for audio performance, user-friendliness and utility in custom installations. The versatility of the Model 275 allows many connection and configuration options, so please be sure to read this manual thoroughly before you begin installation.

Unpacking

Carefully unpack your Model 275 and these accessories:

- Detachable AC power cord
- Trigger wire with a 2.5 mm sub-mini plug at both ends
- Trigger wire adapter for a 3.5mm mini jack

Please inspect the unit now and contact your Parasound Dealer promptly if you see evidence of shipping damage. Save the carton and packing inserts in case you move or in the event you need to ship your amplifier for repair. Before you proceed, locate the serial number on the rear panel or underside of the unit and record it here for future reference:

OWNERSHIP REFERENCE INFORMATION	
Parasound Serial Number:	<input type="text"/>
Date of Purchase:	<input type="text"/> / <input type="text"/> / <input type="text"/>
Name of Dealer:	<input type="text"/>
Dealer Street Address:	<input type="text"/>
Dealer Phone:	(<input type="text"/>) - <input type="text"/>

115v - 230v AC Voltage Selector Switch

This switch is found on the chassis rear panel. The 115V position of this switch is correct for North America; most other regions require setting it to 230V. Make sure the 115/230V switch is set for the correct AC line (mains) voltage before you connect the Model 275's power cord and before you install it. The unit may be seriously damaged if this switch is set incorrectly.

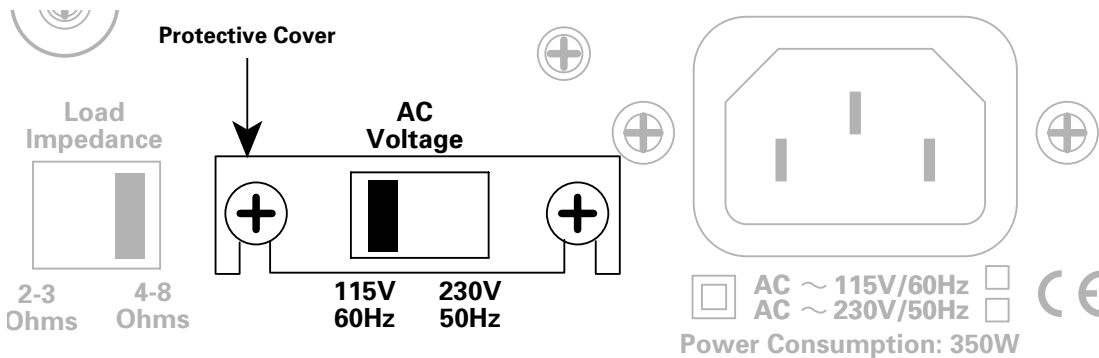

Installation and Ventilation Requirements

Install your Model 275 away from heat sources such as heating ducts, radiators, or other heat producing components. Always position it horizontally.

Observe the following ventilation guidelines when installing the Model 275 in an equipment rack or any other enclosed space:

You should never install the Model 275 in an unventilated equipment cabinet or compartment because hot air will not exhaust adequately to prevent overheating. Air won't often circulate adequately in a cabinet or enclosure whose front and back sides are open; pockets of intense heat can still develop around any heat-producing equipment. Therefore, a ventilation fan is highly recommended. Allow a few inches of empty space on each side and above the unit and try to avoid crowding or stacking the Model 275 tightly between other components. A ventilation fan is also recommended where other equipment must be mounted close to the Model 275.

Do not place the unit on carpeting or any other material that could obstruct air flow into the ventilation holes in its chassis bottom.

Rack Mounting

The Model 275 front panel occupies only one rack space in a standard 19" equipment rack.

For rack mounting, you'll need to use the Parasound RMK11 rack mounting kit (purchased separately). We recommend that you use the 8 insulated shoulder washers with the four mounting bolts which are included with the RMK11. Position these washers on both sides so they "sandwich" the front panel before the mounting bolts are screwed into the rack rail. This will eliminate metal-to-metal contact between the Model 275 chassis, the equipment rack, and the other components in the rack.

REAR PANEL CONNECTIONS AND CONTROLS

Connection Precautions

Disconnect the AC cord before making or changing any input, trigger, or speaker wire connections. Make sure there is no strain or tension on any wires that could cause them to pull loose.

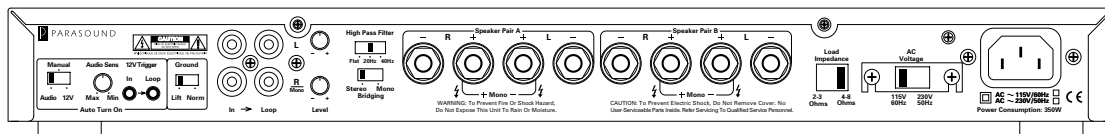

In Jacks

Connect the shielded audio cables from your preamplifier or system controller’s output jacks to the Model 275’s L and R audio Input jacks. Use only the R channel jack for mono operation.

Loop Jacks

The jacks replicate the audio input signals to facilitate connections of other power amplifiers to the same preamplifier or system controller. Loop connection of multiple power amplifiers is called a “daisy chain.”

Note: You may loop the trigger connections of multiple Parasound power amplifiers without overloading the surround controller or preamplifier trigger outputs.

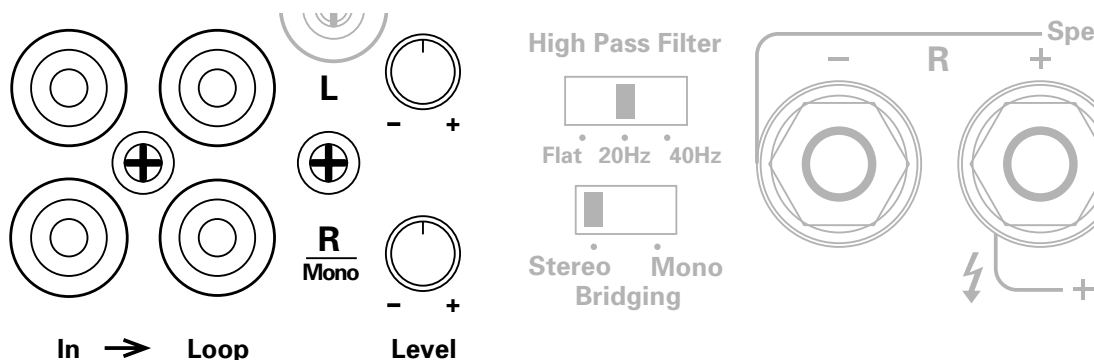

R (Right) and L (Left) Level Knobs

You can increase the listening level for each channel by turning its Level knob clockwise or decrease by turning it counter-clockwise. The 275 has a gain of 28 so that its volume levels are compatible with other channels in your theater if they are driven by a THX-certified amplifier, up to the point where the THX-certified amplifier might play a bit louder because of its higher power output. We recommend setting the 275’s R and L level controls to 3 o’clock if you are driving it from a THX surround controller. This will avoid “clipping” and prevent audible distortion.

Note: You may wish to experiment with different gain settings on your preamp or a non-THX surround controller and on the Model 275 to find a combination of gain settings where your system’s background noise is lowest. Sound professionals call these adjustments “gain staging.”

Note: Only the R channel Level knob is used for bridged mono operation.

High Pass Filter Switch

The High Pass filter can improve the sound in virtually any installation. It's called a "high pass" filter because it permits signals higher than 20 Hz and 40 Hz to pass, while preventing signals below these frequencies from passing.

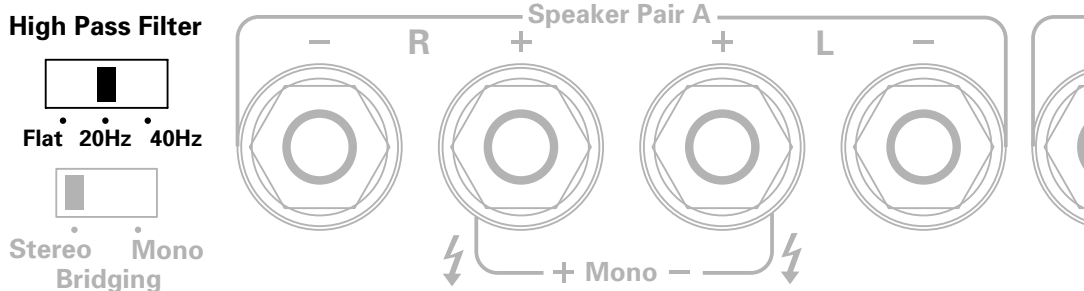

- The Flat switch position disconnects the filter and the 275's frequency response is flat.
- The 20 Hz switch position filters out frequencies below 20 Hz. Your speakers have greater dynamic range and far less distortion when they don't receive frequencies which are lower than they can reproduce. Likewise, the 275 operates more efficiently when it's not called upon to amplify frequencies which the speakers can't reproduce. Because the 20 Hz filter has a steep 18 dB per octave slope, it is essentially a sub-sonic filter, and you probably won't notice any loss of bass unless you're using very large speakers.
- The 40 Hz switch position filters bass below 40 Hz at 18 dB per octave. This is ideal when the 275 is driving in-wall or in-ceiling speakers because very few of them can reproduce very much bass below 40 Hz. You'll enjoy much cleaner sound and higher undistorted volume levels. Not having to amplify bass that's inaudible with your speakers is another way the 275 will run cooler.

Note: Autoformer-type passive volume controls are highly reactive loads that are known to cause amplifier malfunction. The 20 Hz or 40 Hz filter settings enable the 275 to drive them with ease.

Speaker Connections

There are separate speaker terminals for two pairs of speakers, labeled Speaker Pair A and Speaker Pair B.

Each - and + speaker terminal will accept bare speaker wire up to AWG 12, a wire terminated with a ¼" spade lug, or with a single banana plug; dual banana plugs which are ¾" (19mm) apart may be used for each speaker.

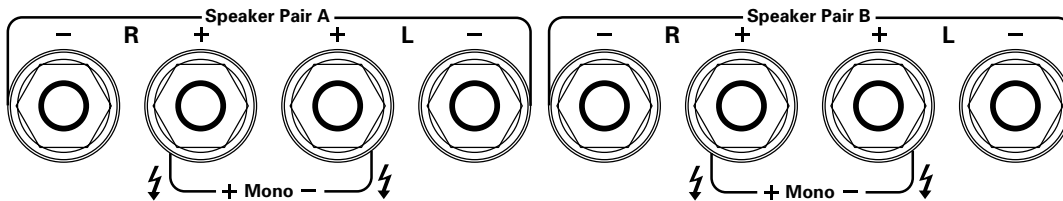

If you use bare wires, remove only enough insulation, about ½" (12mm) for each exposed bare wire to insert through the small hole in the side of the binding post. Before inserting a bare wire, twist the strands tightly between your fingers to prevent strays that might touch the chassis or another terminal and cause a short circuit. If you have soldering experience you may want to "tin" the stripped bare wire with solder for a cleaner termination and to prevent the wire from oxidizing.

Correct Speaker Polarity is Important

As you connect the speaker wires, you can see that the insulation on one of the two wires in each pair has either printing or a raised ridge. The marking lets you know which wire you connected to the positive speaker terminal at its other end.

Make sure the + wire you attach to each Model 275 + speaker terminal is attached to the + terminal of the speaker for that channel.

Bridging Switch: Stereo - Mono

The Model 275 power should always be turned off before moving this switch.

For normal operation the Bridging switch must be set to Stereo.

For bridged mono operation, set it to Mono.

Note: Stereo sound will be faint and very distorted if you accidentally leave the Bridging switch in its Mono position.

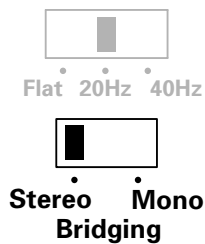
High Pass Filter Mono Operation

We recommend an 8 ohm minimum speaker load for bridged mono operation. For mono the Model 275 "bridges" the R channel to amplify only the positive half of the audio signal and the L channel to amplify only the negative half of the audio signal. In effect, each channel "sees" only half of the speaker's rated impedance, so that an 8 ohm speaker in bridged mono is only a 4 ohm load and a 4 ohm speaker in mono is only a 2 ohm load. This is why the mono power output is much higher than the sum of the L and R channel outputs for stereo operation.

Mono Input and Speaker Connections

1. Turn the unit off and remove the AC cord.
2. Connect the single cable from the preamp or controller to the R channel Input jack.
3. Set the Bridging switch to its Mono position.
4. Connect the positive lead of the speaker wire to the red R + channel speaker pair A terminal.
5. Connect the negative lead of the speaker wire to the red L + channel speaker pair A terminal.
6. Do not connect anything to either the L - or R - speaker terminals.
7. If you have a second mono speaker repeat steps 4 - 6 with the speaker pair B terminals
8. Reconnect the AC cord.

Note: The Model 275 creates more heat when it drives a bridged mono speaker or multiple speaker pairs. Lower impedance speakers will make it run even hotter. Heat greatly reduces the life of the amplifier and nearby components. Please heed the instructions for setting the Load Impedance switch to avoid overheating.

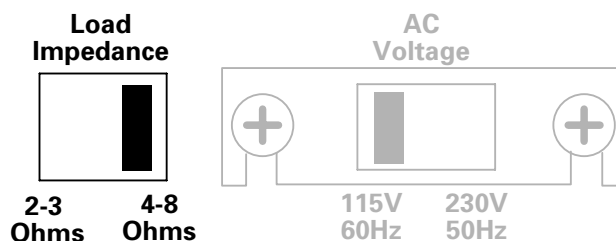
Load Impedance Switch

For a single pair of 4 ohm or 8 ohm speakers the Load Impedance switch may be set to its 4-8 Ohms position. The Load Impedance Switch must be set to 2-3 ohms whenever the load will be lower than 4 ohms. Speaker loads below 4 ohms impedance can cause the Model 275 to over-heat rapidly and cause audible distortion. These are examples that require the 2-3 ohms setting.

1. Driving two pairs of speakers whose impedances you don't know.
2. Driving two pairs of speakers with impedances that are lower than 8 ohms. Two pairs of 4 ohm speakers driven simultaneously are a 2 ohm load.
3. Driving a single 4 ohm speaker bridged to mono. This is a 2 ohm load.
4. Driving two 8 ohm speakers bridged to mono. This is a 2 ohm load.

Note: For the coolest possible operating temperature we recommend setting the Load Impedance switch to 2-3 ohms even if you are using a single pair of 8 ohm speakers.

Automatic Turn On and Off

Auto Turn On Switch

For convenience, there are two ways the Model 275 can be triggered to turn on automatically.

- When a suitable voltage is applied to its 12V In (input) jack.
- When an audio signal is present at the L and R audio Input jacks.

Note: When either automatic turn on method is selected the Model 275 front panel Power button is disabled so that on/off is determined solely by the triggering preamp or system controller.

12V Position

When the Auto Turn On switch is set to its 12V position, the Model 275 is turned on and off with an external +9V to +12V voltage from your preamp or controller. When the external voltage ceases the Model 275 will turn off immediately. The 12V switch position disables the front panel Power button.

Man (Manual) Position

When the Auto Turn On switch is in its MAN (manual) position, the auto turn on function is disabled and the Model 275 must be turned on and off manually with the Power button on its front panel.

Audio Position

When the Auto Turn On switch is set to its Audio position, the Model 275 will be turned on whenever an audio signal is present at its Left and Right Input jacks. After the audio signals cease the Model 275 remains on for about ten minutes. This prevents unintended turn-off during pauses in your music or movies. The Audio position of the Auto Turn On switch also disables the front panel Power button.

Note: You will achieve more consistent auto turn on operation by using the 12V DC trigger if the Model 275 is driving the surround, center, or rear channels. At the beginning of films the surround channel levels are even lower than the minimum level required by the Audio sensing circuit.

12V In Jack

The Model 275 12V input uses a 2.5mm sub-mini jack. To trigger the Model 275, insert the plug at one end of the provided trigger wire into this jack and the other plug at the other end into the source component's trigger output jack.

Some components, including most Parasound Surround Controllers, may use a 3.5mm mini jack for trigger output, so we have also included a 2.5mm jack - 3.5mm plug adapter for your convenience.

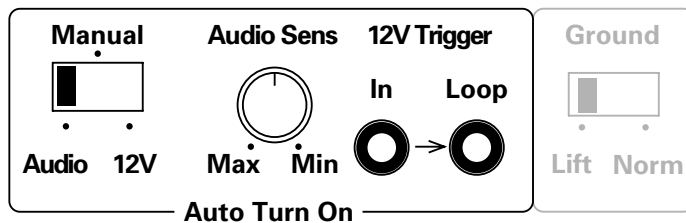

Note: If the controller's trigger output is a + and - terminal, you can cut the 2.5mm plug off one end of the included trigger wire and attach the bare wires to these terminals. The lead with the white stripe on it corresponds to the plug's tip and the unmarked lead corresponds to the sleeve of the plug.

Note: If the trigger voltage source is DC, the trigger plug tip must be + (positive) and its sleeve - (negative).

12V Out Jack

The Trigger Out jack lets you loop or "daisy-chain" the incoming trigger voltage to an additional Model 275 or other component.

Note: The Model 275 trigger circuit draws a negligible 15 mA from the controller. The total load on your controller's trigger output(s) is the sum of the trigger current drawn by each of the components you've looped together. Controllers can typically supply 150 mA at their trigger outputs.

Audio Trigger Sens (Sensitivity) Knob

The Auto Turn On Audio Sensitivity knob adjusts the incoming audio level or the "threshold" required to turn on the Model 275. Its 12 o'clock position will be suitable in most cases. To increase sensitivity for response to lower level audio signals, turn the knob counter-clockwise toward +.

Turn the knob clockwise toward - to decrease its sensitivity. This will prevent spurious noise and switching transients in your system from false-triggering the Model 275.

Note: Plugging in the 275's AC cord for the first time will usually create an internal power surge that "false triggers" its Audio auto turn on, even if there's no audio signal at its input jacks, and it will remain on for 10-15 minutes after you switch it off. This is normal.

Ground Switch

Ground is the normal position for this switch. If you hear background hum in the speakers connected to the Model 275, try setting the Ground Lift Switch to its Lift position. The Ground Switch disconnects or "lifts" the audio circuit ground from the chassis ground. This often helps to eliminate audible hum that results from ground loops. Ground loops are multiple ground paths such as the metal-to-metal contact with the panels or chassis of other components combined with the ground connections of the audio cables or even the ground wires of the various AC cords.

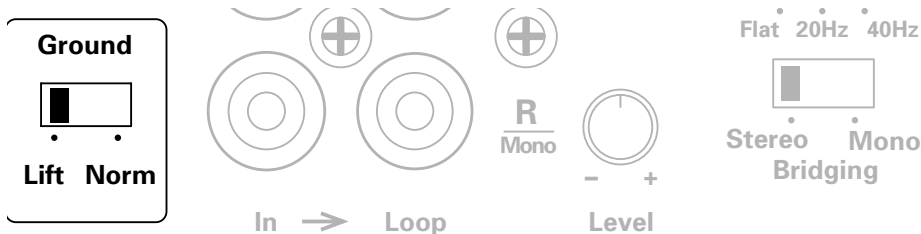

AC Power Connections and AC Grounding

If possible, plug your Model 275 into the same AC outlet that your accompanying audio components (especially then preamp or system controller) are plugged into. The ground potential between different AC outlets may be higher or lower, resulting in audible hum.

Power Button

Press the Power button once to turn the Model 275 on, press it again to turn it off. The Power button is inoperative when the Auto Turn On switch is set to Audio or 12V.

Note: It is normal for the 275 Protect indicator to flash briefly right after turn on.



A and B Speaker Select Buttons

These buttons turn on the speaker pairs connected to the corresponding Speaker Pair A and B terminals. They will also select two single mono speakers.

Note: The front panel buttons and switches activate relays which perform the actual speaker switching. The contacts in the relays will last longer if you don't press the A and B buttons to turn speaker pairs on and off while the 275 is playing at high volume.

Protect Indicator

The Protect indicator will illuminate red if the Model 275 experiences an external fault condition and the unit will stop playing. This prevents possible damage to the unit from continued operation. Examples of external fault conditions are short circuited speaker wires, excessive heat, and trying to drive too many speakers at high levels.

If Protect is illuminated you need to locate and correct the fault; for example, remove the short circuit, let the unit cool down, check the load impedance and the setting of the Load Impedance switch, lower the volume level. To reset the protection circuit you need to turn the unit off.

Turning it off:

- Auto Turn On switch (on the rear panel) in the Man position: press the Power button on the front panel.
- Auto Turn On switch in the 12V position: turn off the 12V trigger source; the 275 will turn itself off right away. You can also turn it off by unplugging its AC power cord.
- Auto Turn On switch in the Audio position: turn off the preamplifier, surround controller or system controller that drives your 275. You can also unplug the 275's AC power cord.

Note: It requires approximately 15 minutes after removing the audio source before the 275 turns itself off. If you don't want to wait and you have access to its AC cord, simply unplug it. Leave it off and/or unplugged for awhile to cool down and you're confident the fault is corrected. If you unplugged its AC power cord to turn it off, plug it in again.

Hi-Temp Indicator

Hi-Temp will illuminate red when the Model 275 exceeds its maximum safe operating temperature. If the heat persists, the unit will activate its protection circuit and stop playing. It will remain in this protection mode until the temperature drops and the unit is turned off to reset its protection circuit. Use the same turn-off procedure as above. If Hi-Temp appears, it's likely the unit is been over-driven at too high a listening level or is attempting to drive a speaker load impedance that is too low. It's probable the unit has not been provided with sufficient ventilation. These conditions must be corrected before turning it on again to resume operation.

L and R Channel Status Indicators

L and R will illuminate green when the Model 275 power is on and it is operating normally. The L indicator will not light if a fault is only in the left channel; the R indicator will not light if a fault is only in the right channel. Neither L or R indicators will illuminate if there is a general fault or if the temperature is too high.

Maintaining Your Model 275

Your Parasound Model 275 power amplifier requires no periodic maintenance other than the knowledge that you are bragging about it to your friends. It has no user-serviceable parts inside. To avoid the risk of electric shock, do not remove its top cover. The exterior can be cleaned with a soft cloth pre-moistened only with a few drops of water or glass cleaner.

Troubleshooting**No sound**

- Check that AC is live.
- Is the unit on? Check the setting of the Auto Turn On switch.
- Doesn't turn on with the Auto Turn On - Audio. Try the 12V trigger instead.
- Check that input cables and speaker wires are secure at both ends.
- Make sure the control preamp/receiver is switched to the correct input.
- If using Auto turn on, increase the sensitivity of the audio trigger.
- Is the Hi-Temp or Protect (or both) illuminated? Check for excessive temperature, short circuited speaker wires, low impedance speaker load, and inadequate ventilation to remove heat.

Background Hum

- Move the Ground switch to Lift.
- Move audio cables and AC cords away from each other.
- Try different routes for the audio cables and AC cords.
- Make sure insulating shoulder washers are used if unit is rack mounted.
- Try reversing the direction of each other component's AC plug, one by one.

Overheating

- Remove any external sources of heat.
- Increase ventilation around the Model 275.
- Reset the Load Impedance switch to 2-3 Ohms.

Call your Parasound dealer first. If the dealer can't help you with your problem we encourage you to call Parasound's Technical Service Department, toll-free at **1-866-770-8324**, Monday - Friday, 8am - 4pm Pacific time. We can suggest other diagnostic tests you can easily perform. If we determine that your Model 275 should be returned to Parasound or an Authorized Parasound Warranty Center for inspection and possible servicing, we will provide the location of a warranty center near you or shipping instructions and a Return Authorization number for its return to Parasound.

Before You Return Any Unit to Parasound for Service

Before you send your unit to Parasound, you will need to obtain a specific Return Authorization (RA) number and shipping instructions from Parasound's Technical Department. The RA number must be clearly marked on the outer carton. Use the original factory packing materials and arrange adequate insurance to cover its value. You must include a copy of your purchase receipt, since this document establishes the validity of this unit's warranty. Warranty repairs are only performed by Parasound or Parasound Authorized warranty centers when your purchase receipt is from a Parasound Authorized Dealer or Parasound Authorized Reseller.

Units Will Be Refused by Parasound Under the Following Conditions

1. Unit was sent without the Parasound-assigned RA number marked on the carton.
2. Unit was sent in an unsuitable shipping carton, likely to have been damaged in transit.
3. Unit has inadequate packing, unit likely to have been damaged in transit.
4. Unit was shipped collect for shipping charges. We do not accept collect shipments.
5. Unit was shipped via the US Postal Service.
6. Unit was sent to an address other than the address instructed by our Technical Department.

Note: The shipping address is not the same as Parasound's office address.

Warranty Repair

Read your accompanying Parasound Limited Warranty carefully to understand the applicable rights and limitations. This section provides instructions for obtaining repairs, both for units covered under the Parasound Limited Warranty and for units or situations which are outside the Warranty.

Unit is not eligible for repair under the terms of the Parasound warranty if:

1. Unit was not purchased from a Parasound Authorized Dealer or Parasound Authorized Reseller.
2. You are not the original owner. The warranty is not transferable.
3. Unit's serial number was removed, modified, or defaced.
4. Unit shows evidence of abuse and/or misuse.
5. Unit was modified in any way.
6. A prior repair was attempted by an unauthorized repair station.

Continuous RMS Power Output**20 Hz – 20 kHz, Both Channels Driven**75 watts x 2, 8 Ω 120 watts x 2, 4 Ω 120 watts x 2, 2 Ω **Continuous RMS Power Output****20 Hz – 20 kHz, Bridged Mono**200 watts, 8 Ω 200 watts, 4 Ω **Current Capacity**

20 amps peak per channel

Frequency Response

20 Hz - 50 kHz, +0/-3 dB, 1 watt

Dynamic Headroom

1.3 dB

Total Harmonic Distortion

0.035% at full rated output

0.025% at average listening levels

IM Distortion

0.05 %

Transient IM Distortion

Not measurable

S/N Ratio

110 dB at rated output, IHF A-weighted

103 dB at rated output, unweighted

93 dB at 2.828 V output, IHF A-weighted

84 dB at 2.828 V output, unweighted

Input Impedance33 k Ω **Input Sensitivity**

800 mV for full rated output

Inter-Channel Crosstalk

80 dB, 1 kHz

72 dB, 10 kHz

65 dB, 20 kHz

Damping Factor

Over 150 at 20 Hz

Auto Turn On – DC

9 – 12V, 15 mA

Auto Turn On – Audio

1.2 mV – 12 V, adjustable

15 minute turn off delay

AC Power Requirement

110 - 120 V / 220 -240 V, 50 - 60 Hz

3 watts standby; 350 watts full output

Dimensions

17¼" Wide

16" Deep, with connectors

2½" High with feet, 1¼" panel only

437 x 406 x 63mm, 44.1 mm panel only

Net Weight

21 lbs , 9.6 kg

Rack Mount Accessory

May be Purchased Separately

RMK11

We invite you to visit www.parasound.com for the most up-to-date information on your unit and to find out about other Parasound products. Learn why Parasound has been a quality and value favorite of magazine reviewers, sound professionals and listeners like you since we were founded in 1981.



PARASOUND®

Parasound Products, Inc. 950 Battery Street, San Francisco, CA 94111
Customer Service 415-397-7100 / Technical Dept. 415-675-7272 / Fax 415-397-0144
www.parasound.com